

# YVC7V-U / YVC7V-R (TSE) / NYCY (VDE)

0.6/1 kV Alçak Gerilim  
Güç Kabloları  
0.6/1 kV Low Voltage  
Power Cables

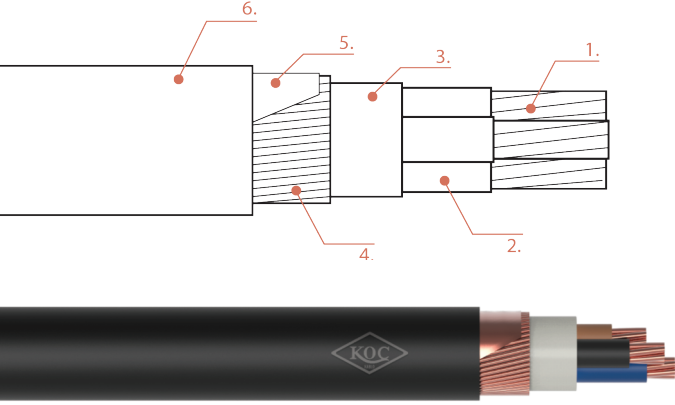

## YAPISI / CONSTRUCTION

1. Bakır İletken
2. PVC İzole
3. PVC Dolgu
4. Bakır Konsantrik Siper
5. Bakır Tutucu Bant
6. PVC Dış Kılıf

1. Copper Conductor
2. PVC Insulation
3. PVC Filler
4. Copper Concentric Screen
5. Copper Retaining Tape
6. PVC Outer Sheath

**Standartlar:** TS IEC 60502-1, VDE 0276

## TEKNİK BİLGİLER

Max. Çalışma Sıcaklığı:	70°C
Min. Bükülme Yarıçapı:	12xD
Anma Gerilimi:	0.6/1 kV
Max. Kısa Devre Sıcaklığı:	≤300 mm <sup>2</sup> 160°C >300 mm <sup>2</sup> 140°C

## TECHNICAL DATA

Max. Operating Temp:	70°C
Min. Bending Radius:	12xD
Rated Voltage:	0.6/1 kV
Max. Short Circuit Temp:	≤300 mm <sup>2</sup> 160°C >300 mm <sup>2</sup> 140°C



## KULLANIM YERLERİ / APPLICATIONS

- Genellikle yerleşim bölgelerinde, toprak altında kullanılan bu kabloların üzerinde bulunan konsantrik iletken herhangi bir mekanik darbe esnasında şebekeye bağlı olan şalter yada sigortayı açtırarak enerjinin çevreye zararını önler.
- Generally used underground in residential areas, the concentric conductor on these cables, which are generally used under the ground in residential areas, prevents the energy damage to the environment by opening the switch or fuse connected to the network during any mechanical impact.

# YVC7V-U / YVC7V-R (TSE) / NYCY (VDE)



PVC İzoleli Bakır Konsantrik Siperli Çok Damarlı Güç Kabloları

PVC Insulated Copper Concentric Screened (or Shielded) Multi-core Power Cable

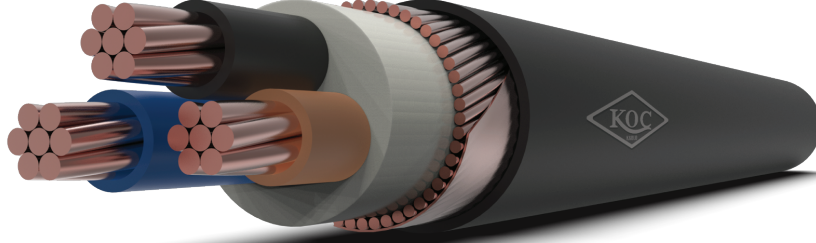

Nominal Kesit (mm <sup>2</sup> )	Dış Çap (mm) Yaklaşık	Net Ağırlık (kg/km) Yaklaşık	20°C'de İletken DC Direnci (ohm/km)	Akım Taşıma Kapasitesi	
				Toprakta (A)	Havada (A)
Nominal Cross Section (mm <sup>2</sup> )	Overall Diameter (mm) Approx	Net Weight (kg/km) Approx	Conductor DC Resistance at 20°C (ohm/km)	Current Carrying Capacity In	
				Ground (A)	Air (A)

## YVC7V-U / YVC7V-R (TSE) / NYCY (VDE)

Nominal Cross Section (mm <sup>2</sup> )	Overall Diameter (mm) Approx	Net Weight (kg/km) Approx	Conductor DC Resistance at 20°C (ohm/km)	Current Carrying Capacity In Ground (A)	Current Carrying Capacity In Air (A)
3x1.5/1.5	13.0	230	12.1	27	19
3x2.5/2.5	14.0	300	7.41	36	25
3x4/4	16.0	400	4.61	47	34
3x6/6	17.0	500	3.08	59	43
3x10/10	19.0	700	1.83	79	59
3x16/16	22.0	1000	1.15	102	79
3x25/16	26.0	1400	0.727	133	100
3x35/16	29.0	1800	0.524	159	125
3x50/25	32.0	2350	0.387	188	153
3x70/35	37.0	3200	0.268	232	195
3x95/50	42.0	4300	0.193	280	238
3x120/70	45.0	5300	0.153	318	275
3x150/70	50.0	6400	0.124	359	320
3x185/95	55.0	8050	0.0991	406	364
3x240/120	63.0	10500	0.0754	473	430
3x300/150	69.0	13100	0.0601	535	510
3x400/185	77.0	16400	0.0470	613	595